



INSTALLATION MANUAL

CLASSIC WEATHERBOARDS



EXTERNAL CLADDING 2022

A better choice, naturally

Contents

- Introduction.....3
- Accreditations4
- 1 GENERAL INSTALLATION INFORMATION5**
 - 1.1 Product Information5
 - 1.2 Fire Rated Wall Systems6
 - 1.3 Physical Properties7
 - 1.4 NCC Compliance8
 - 1.5 General Requirements9-11
 - 1.6 Painting: Pre-Primed.....12
 - 1.7 Maintenance13
 - 1.8 Steel Frames14-15
 - 1.9 Cavity System16-17
- 2 CLASSIC WEATHERBOARDS / SHINGLES PLUS18**
 - 2.1 Classic Weatherboards19
 - 2.2 Accessories20-21
 - 2.3 Fasteners22-23
 - 2.4 Installation24-26
- MANUFACTURERS WARRANTY27**

ALL OTHER WEATHERTEX PRODUCTS

To view and read all other Weathertex product installation manuals visit weathertex.com.au

Introduction



MADE IN AUSTRALIA

Family owned and manufactured in the Hunter region, NSW since 1939.



SAFE

Low VOC. Meets Australian Building Standards. 100% natural product. No silica, glues, resins or formaldehydes.



TRUSTED

WeatherTex voted #1 MOST TRUSTED brand in the building industry by Architecture & Design latest survey. Won SUPPLIER OF THE YEAR in the Australian Construction Awards.



STYLISH CHOICES

A wide selection of profiles available in various styles, textures and sizes. Easy to incorporate the natural with primed profiles together to offer multiple design options.



SUSTAINABLE

Better than zero carbon footprint with Third Party Credentials - GreenTag certification, PhD, PEFC. Low embodied energy.



VALUE FOR MONEY

No special tools required for cutting. Lightweight product - reduces labour costs.



DURABLE

Termite Resistant. Warranty tried and tested not to rot, split or crack for up to 25 years. 1000 kg/m³ product density with a minimum 32MPa rating. Watertight - mechanical flashing and joining accessories mean that sealant control joints are seldom required.



QUICK & EASY INSTALLATION

Larger weatherboards for quick installation. 9.5mm thickness and matching accessories across all products making it easier to mix multiple profiles within a project. Easier to paint than other materials on the market due to its smoother surface.



Accreditations

The CodeMark Certification Scheme (the Scheme) is a voluntary third-party building product certification scheme that authorises the use of new and innovative products in specified circumstances in order to facilitate compliance with Volumes One and Two of the NCC, also known as the Building Code of Australia or BCA.

CodeMark provides confidence and certainty to regulatory authorities and the market through the issue of a Certificate of Conformity, which is one of several options available for meeting the 'evidence of suitability' requirements of the BCA.



Our 'Green' Accreditations

A rigorous life-cycle evaluation has been conducted by Global GreenTag International to determine the 'environmental performance' of our products. We are proud to announce we have been the FIRST GLOBAL manufactured product to receive their highest Platinum certification for our Natural Range and a Gold certification for all our flat primed profiles.



PRIMED RANGE
IS GOLD GREENTAG
CERTIFIED.

2018 Supplier of the Year at the Australian Construction Awards.

The industry relies on a number of stakeholders to keep projects moving. Supplier of the year is a company that provided quality, on time, every time.



A&D's Most Trusted Brand Award x 2 consecutive wins (2016 & 2018). Architecture and Designs 'Top Trusted Brand' biennial survey reveals Australia's top brands within the architecture, building, construction and design industries

Weathertex sources timber from sustainably managed forests and controlled sources audited under the Australian Forestry Standard (AFS) and Certified by PEFC: the world's largest forest certification scheme.

Whether you are seeking timber cladding for a renovation, extension, new home, or commercial application, Weathertex weatherboards and architectural panels offer an endless variety of timber cladding solutions and styles.



A better choice, naturally.



1.1 Product Information

1.1.1 DIMENSIONS AND PACKAGING

TRADITIONAL WEATHERBOARDS	LENGTH (mm)	WIDTH (mm)	UNITS PER PACK	CONTENTS m ²
Classic 200	3660	197	144	103.8
Rusticated	3660	197	144	103.8
Shingles Plus	1196	225	120	32.3

1.1.2 WEATHERBOARD WALL COVERAGE TABLE

	CLASSIC 200	RUSTICATED	WALL SHINGLES
Weatherboard Width	200	200	225
Weatherboard Lap	20	25	40
NUMBER OF ROWS (x)	WALL HEIGHT COVERAGE (mm)		
Approximation	= 177x + 20	= 172x + 25	= 185x + 40
1	197	197	225
2	374	369	410
3	551	541	595
4	728	713	780
5	905	885	965
6	1082	1057	1150
7	1259	1229	1335
8	1436	1401	1520
9	1613	1573	1705
10	1790	1745	1890
11	1967	1917	2075
12	2144	2089	2260

NOTES:

1. Manufacturing and installation tolerances apply
2. At the wall/eave intersection a timber cover strip or quad may be fixed for a tidy finish
3. Checking row height alignment around corners is important to avoid creep due to small differences in board tolerances and tightness of installation

1.2 Fire Rated Wall Systems

Weathertex has been assessed by an Accredited Testing Laboratory, that the attachment of Weathertex 9.5mm cladding systems detailed in Table 1.2.1 over plasterboard timber and steel plasterboard lined walls that has been either tested or assessed to achieve an FRL up to and including 90/90/90, would not detrimentally affect the FRL of the underlying wall system if testing in accordance with AS 1530.4:2014.

1.2.1 TABLE - ALLOWABLE FIXING OPTIONS OVER PLASTERBOARD FRL SYSTEMS

CLADDING SYSTEM	UNDERLYING PLASTERBOARD SYSTEM	
	TIMBER FRAMING	STEEL FRAMING
Direct fix	✓	✗
9.5mm Weathertex cavity system	✓	✗
20mm Pine batten cavity system	✓	✓
35mm Pine batten cavity system	✓	✓
45mm Pine batten cavity system	✓	✓
Steel top hat (min 0.55 BMT G550)	✓	✓

These fire rated wall systems are detailed by the relevant system manufacturer such as USG Boral. Advice of the system manufacturer should be sought on the appropriate system for your project.

All walls must be designed for the applied loads. For load-bearing walls and walls subject to wind pressures, walls shall be designed to the appropriate Australian Standards or construction manuals. Designers should consider Axial Capacity Reduction (ACR) from charring or loss of steel strength due to heat. Guidance on structural design can be sought from the relevant FRL system manufacturer.

Standard installation requirements in this installation guide apply to the installation of the Weathertex external cladding component. Fastener lengths must be increased by the thickness of all packing materials used between the structural frame and Weathertex.

USG BORAL Systems+ OUTERWALL.



EXAMPLE FRL SYSTEM DESCRIPTION (60/60/60 Outside only)

EXTERNAL WALL SIDE

- Weathertex 9.5mm Cladding
- Vapour permeable membrane
- 1 layer 16mm FIRE WETSTOP

CAVITY INFILL:

- R2.5 GW Wall Batts

INTERNAL WALL SIDE

- 1 layer of 10mm STANDARD Plasterboard

1.3 Physical Properties

WEATHERTEX WEATHERBOARDS AND ARCHITECTURAL PANELS.

WeatherTex weatherboards and architectural panels have been comprehensively tested to Australian and International Standards for verification of compliance to the Building Code of Australia.

MATERIAL DURABILITY PROPERTIES

The Product Specification Standard for WeatherTex is AS/NZS1859.4 - Wet Processed Fibreboard for Exterior Conditions (HB.E).

PROPERTY	STANDARD	RESULT	REQUIREMENT
Dimensions	AS NZS 4266.1	PASS	±2mm/m
Density	AS NZS 4266.1	1000 kg/m ³	> 750 kg/m ³
Bending Strength	AS NZS 4266.1	32 MPa	> 20 MPa
Modulus of Elasticity	AS NZS 4266.1	4500 MPa	> 2900 MPa
Equilibrium Moisture Content	AS NZS 4266.1	7.5%	7.5% ± 1% @ Factory gate
Dimensional Stability - Hygro-Expansivity	AS/NZS 4266.1	0.16% change in face dimensions over the range of 35%-80% relative humidity	N/A
Moisture Resistance	AS NZS 4266.1 - 24 Hour submersion	< 2% Swell	8% Max.
		< 6% Absorption	12.5% Max.

THERMAL AND ACOUSTIC PROPERTIES

PROPERTY	9.5MM COMPONENT VALUE	WEATHERTEX SYSTEM
Thermal Conductivity	0.22 W/mK	Where thermal and acoustically rated walls are required: WeatherTex can be used as part of wall systems to meet your specific performance requirements.
Thermal Resistance	0.04 m ² K/W	
Acoustic Properties (Rw)	System Dependant	

FIRE PROPERTIES

PROPERTY	STANDARD	RESULT	REQUIREMENT
Bushfire Attack Level (BAL)	AS 3959	Up to and including BAL 19	BCA: Vol. 1 - G5.2 BCA: Vol. 2 - 3.10.5
Average Specific Extinction Area	AS/NZS 3837	38.7 m ² /kg	BCA: Vol. 1 - C1.10
Material Group Number	AS/NZS 5637.1	Group 3	BCA: Vol. 1 - C1.10 BCA: Vol. 1 - Spec C1.10 - 4
Early Fire Hazard Indices	AS 1530.3	Ignitability : 12 Spread of Flame: 5 Heat Evolved : 4 Smoke Developed: 2	BCA: Vol. 1 - C1.10
Fire Resistance Level (FRL)	AS1530.4	Systems up to 120/120/120 available	BCA: Vol. 1 - Spec C1.1
Combustibility	BCA: Vol 1 - C1.1	Type C Compliant*	BCA: Vol 1 - C1.1

* A class 2,3 or 9c building with a rise in storeys of 2 may be of type C construction if requirements of C1.5 are satisfied.

MISCELLANEOUS PROPERTIES

Formaldehyde Classification	AS/NZS 4266.16 Test Method: <0.07 mg/L – Emission Class Super EO
WeatherTex contains no silica, resins, binders or added formaldehydes and the results above confirm the amount naturally present in hardwood timber is negligible and well below the acceptance level of 1.0mg/L (E1).	

1.4 NCC Compliance

Evidence of Suitability supporting the use of Weathertex to meet relevant Performance Requirements and Deemed-to-Satisfy requirements are available. Please contact the Weathertex technical team (ph:1800 040 080) for relevant compliance documentation or visit our website - weathertex.com.au.



Image: Classic Smooth

1.5 General Requirements

The following installation instructions and guides are in addition to local and state regulations and the requirements of the National Construction Code (NCC). Weathertex provides construction detail drawings which should be used in conjunction with the instructions in this installation manual.

NOTE: All diagrams in this installation manual are for demonstration purposes only. Diagrams may omit some components for clarity.

Deviation from standard applications and requirements detailed in this Installation Manual or supplementary Weathertex Construction Details may void the manufacturer's product warranty. The product specific installation instructions in this manual are applicable to steel and timber frames for both direct fix and cavity systems. Preparation steps must be followed for direct fix to timber frame, ventilated cavity construction and steel frame construction.

1.5.1 STORAGE AND HANDLING

Weathertex products should be stored flat, under cover and on timber bearers spaced at maximum 600mm centres. When storing Weathertex outside, keep the stack clear of the ground and cover with waterproof materials to prevent water staining.

NOTE: Weathertex factory stretch wrap is not designed to keep stored product weatherproof and should not be relied upon for primary weather protection.

Anodised aluminium products should be stored in a dry and flat position away from any potentially corrosive or incompatible materials. Timber or soft bearers at a distance no more than one metre apart should be used to support the product. Continuous exposure to moisture will promote corrosion. Metal edges and cut corners of the product can be sharp and may cause personal injury if not handled safely. Wear eye protection, gloves and protect skin when possible and when cutting avoid air borne metal fragments.

1.5.2 CUTTING AND WORKING WITH WEATHERTEX

Weathertex products are easy to cut and shape with a normal hand or power saw. Weathertex may be stacked two or three high for multiple cutting. Where required, edges may be trimmed with a smoothing plane or sandpaper. Holes are easily drilled with high speed drills or clean cutter bits. For best results break cut edges with a 2mm chamfer. Clean all dust from flashing as work progressed, as it may mix with water and create a brown runoff. Cut edges, holes and countersinks must be re-primed with a high quality tannin blocking exterior timber primer (water or solvent based). Excluding our Natural range.

The normal health and safety precautions should be taken when working with wood panel products. Machining equipment should be fitted with dust collection devices and used in well ventilated areas. Follow good hygienic and housekeeping practices. Wood dust can be vacuumed, shovelled or swept to avoid accumulation. If dust levels exceed Safe Work Australia Standards the wearing of a dust mask (AS 1715 and AS 1716) and safety glasses (AS 1337) is recommended. Storage and work areas should be adequately ventilated.

A Safety Data Sheet is available for download on the Weathertex website: weathertex.com.au

1.5.3 SITE, FOUNDATION AND FRAMING

Foundation design must comply with AS 2870 "Residential Slabs and Footings - Construction" and the National Construction Code (NCC). Timber or steel frames shall comply with the NCC. Where applicable, timber frames shall be constructed in accordance with Australian Standard 1684 - Residential Timber - Framed Construction. Steel frames must be erected in accordance with the manufacturer's requirements. Frames shall be straight and true with studs at a maximum of 600mm centres. Timber shall be seasoned, as unseasoned timber is prone to shrinkage and can cause sheets and frames to move.

1.5.4 GROUND CLEARANCES

Lower framing timbers must be isolated from ground moisture by suitable damp-proof courses (DPC) or termite shielding. Similarly, weatherboards must not be placed in direct contact with masonry, brickwork or concrete. Where necessary, use strips of Alcor to isolate the materials. The bottom edge of weatherboards must be kept clear of paved surfaces by a minimum of 100mm and a minimum of 225mm for unprotected ground (i.e. grass, gardens etc). Weatherboards must extend a minimum of 50mm below the bearer or lowest horizontal part of the of suspended floor framing for a suspended floor system. The grade of adjacent finished ground must slope away from the building to avoid the possibility of water accumulation. Typically this is a minimum slope of 50mm over the first metre, however please refer to the minimum slope required from local building codes and regulations. Weathertex must not be installed in wet areas and where it comes in contact with standing water.

NOTE: To comply with termite protection provisions a greater clearance may be required. See 'Weathertex and Termite protection' in section 1.5.10.

1.5 General Requirements

1.5.5 LENGTH OF WALL REQUIREMENTS

For continuous walls less than 11m, all product specific joining methods may be used on continuous walls greater than 11m, traditional, traditional & aluminium joining methods must only be used. For continuous walls greater than 11m long, engineers/designers must assess additional requirements for frame and cladding control joints, alternatively please call Weathertex (Ph 1800 040 080) for additional advice.

NOTES:

- For specific joining methods applicable to each product, refer to specific product section.

1.5.6 MOISTURE MANAGEMENT AND FLASHING

Weathertex weatherboards are intended for use as internal and external cladding in standard stud wall systems. It is the responsibility of the Designer or Specifier to identify moisture related risks associated with any particular building design. Wall construction and design must effectively manage moisture, considering both the interior and exterior environments of the building, particularly in buildings that have a high risk of wind driven rain or are artificially heated or cooled. Adequate design of ventilation, flashings and moisture management systems must ensure that the wall cavity and the back of the Weathertex board will remain dry at all times.

In addition, all wall openings, penetrations, junctions, vertical and horizontal joins, connections, window heads, sills and jambs or other components, must incorporate appropriate NCC complying flashing for waterproofing to prevent moisture exposure on the back of the Weathertex. Flashing materials and methods must comply with the requirements of Weathertex, and where flashing materials are not specified by Weathertex refer to the Australian Standards &/or NCC. Failure to appropriately flash all penetrations will void the Weathertex Manufacturer's Warranty.

On walls projecting from the roof line in upper storey construction, keep the bottom edge of Weathertex cladding 70mm clear of the lower storey roof claddings. Weatherproof with an approved flashing. For product specific details please refer to the relevant construction details on weathertex.com.au.

1.5.7 WALL SARKING REQUIREMENTS

Vapour permeable membrane must be used under all Weathertex external wall systems. The vapour permeable membrane allows for the controlled escape of vapour from within the building whilst restricting the ingress of liquid moisture.

Weathertex recommends the use of Vapour permeable membrane in conjunction with the Weathertex Cavity Installation System to provide the best protection against condensation problems such as mould, timber rot, corrosion and loss of thermal resistance. Resources such as the ABCB Condensation Handbook and NATSPEC offer general information on condensation principles.

NOTE: Soft compressible products such as insulation installed directly between the front of the wall studs and Weathertex cladding is not compatible with Weathertex products and will void the product warranty.

SARKING REQUIREMENTS FOR CLIMATE ZONES 2 - 8

Material Standard	AS/NZS 4200.1
Installation Standard	AS 4200.2
MANDATORY PROPERTIES	
Vapour Resistance	Class 4
Water Barrier	Passing AS/NZS 4201.4
Flammability index	NOT MORE THAN 5

*sarking products are unsuitable if classed as a "Non-water Barrier" as per AS/NZS 4200.1 clause 5.3.5. and will void the Weathertex product warranty.

1.5.8 RECOMMENDED VAPOUR PERMEABLE MEMBRANE PRODUCTS

The permeability and vapour resistance of materials should be considered in the context of their application. The designers/architects/engineer should consider strategies to mitigate condensation risks in the design with relevance to local climate conditions. Suitable membrane products for moisture control in hot wet and humid conditions (Climate Zone 1) should be discussed with the membrane manufacturer.

Recommended accessories required for AS 4200.2 installation are Waterproofing tapes such as Bradford Enviroseal™ HighTack Adhesive Tape & Pro clima TESCON EXTORA® or equivalent, and Sill tapes such as Enviroseal™ Proctorwrap SLS Flexi Tape & Pro clima TESCON EXTOSEAL® or equivalent.

		Product: Enviroseal Proctor Residential (RW) OR Commercial (CW)	
		Product: Ametalin VapourTech® Wall Residential & Commercial	
		Product: Thermakraft Watergate Plus	

1.5.9 CONSTRUCTION DETAILS

Please refer to the Weathertex website for the complete suite of construction details for all products and applications weathertex.com.au

1.5.10 WEATHERTEX AND TERMITE PROTECTION

The NCC specified the requirements for termite barriers. All of these requirements must be satisfied. Where the exposed slab edge is used as a part of the termite barrier system, a minimum of 75mm of the exposed slab edge must be visible to permit ready detection of termite entry.

Weathertex currently provides a warranty which protects against a variety of conditions including (but not exclusive of) the product supplied being fit for purpose, and will not rot, split or crack. In addition to this, Weathertex is warranted against termite attack, provided the following conditions are adhered to.

A termite mitigation plan complying with all local, state and federal requirements and best-practice guidelines must be in place and maintained from the time that the Weathertex is delivered to site and for the life of the product. Provided that the plan and its maintenance can be demonstrated, the normal Weathertex warranty at the time of purchase will apply to the Weathertex.



Samples removed from Termite Test after 2.5 years exposure

1.6 Painting: Pre-Primed

1.6.1 PRE-PRIMED PRODUCTS

PRIMER:

Weathertex factory primer is designed to be painted within 60 days of installation. Failure to do so can result in poor topcoat adhesion and will void warranty. Lightly sand any nibs or blemishes which have occurred during fixing. Cut edges, holes and countersinks must be re-primed with high quality tannin blocking exterior timber primer (water or solvent based). A spray primer is the most efficient method. It is also good practice to prime any timber mouldings, including corner stops and trims.

Trimtec aluminium accessories are protected by an anodised coating and can be left unpainted if desired. Due to their smooth surface, aluminium accessories should be etch primed if a topcoat is to be applied.

SURFACE PREPARATION - CLEANING & WASHING:

Clean surface of primed Weathertex products using a soft broom or soft lint-free cloth and wash down with sugar soap to remove salt, dirt, dust and grease or airborne contaminates. Do not vigorously scrub the surface nor use an abrasive or strong cleaning agent as you may burnish the paint surface and mark the primer finish. Wash down with fresh water and dry the surface with one final wipe using a soft dry lint-free cloth in the direction of the paint flow. Do not use high pressure washers as this can cause coating damage and water ingress into the wall cavity.

Not allowing the Weathertex to dry before painting is a common cause of paint failure. Failure to clean the surface may result in poor adhesion with topcoat and may void warranty.

1.6.2 PAINTING PRE-PRIMED PRODUCTS

PAINTING:

The primed surface of Weathertex products are suitable for the application of exterior grade water or solvent based topcoat paint systems. It is recommended to apply selected coating to a test area to confirm suitability. If compatibility of the selected topcoat is an issue, the surface may be primed with a suitable tannin blocking exterior primer per the coating manufacturer's recommendation before painting. Contact the paint manufacturer for advice or information.

When top coating, apply a minimum of two coats of paint in accordance with the paint manufacturer instructions for mixing, film build, coverage and drying between coats. Temperature and wet weather will affect curing of coatings and consideration of site conditions at the time of painting is essential to ensure proper curing and adhesion. Paint additives may adversely affect the coating adhesion and durability and should only be used with the endorsement of the coating manufacturer.

PAINT COLOUR:

Weathertex hardboard products have 50 years proven durability in the harshest of climate zones. While there is no restriction on the vast array of colours to paint your home, it is important to understand the effect paint colours can have on the performance of construction products.

As Weathertex is a timber product, its dimensions will expand and contract with changes in moisture content. Dark paint colours can allow surfaces in warmer climates to become very hot in direct sunlight leading to loss of moisture and subsequent shrinkage of the weatherboard. Selection of light paint colours with high Light Reflectance Values (LRV) will lead to better thermal efficiency of the building, improve the maintenance cycles of paint coatings and sealants while minimising the thermal expansion and contraction of all construction components. With darker paint colours we recommend prepainting the ends of the weatherboard prior to installation of joining/corner accessories.

NOTE: Weathertex Classic Shingles Plus Natural can be stained or left to naturally lighten with UV exposure. For details on staining or uncoated natural Weathertex, please refer to the Selflok installation manual or call customer service on 1800 040 080. These details must be followed for the Weathertex Manufacturer's Warranty to apply. This is only permitted for Natural Weathertex products.

1.7 Maintenance

1.7.1 PRE-PRIMED PRODUCTS

The extent and nature of maintenance will depend on the geographical location and exposure of the installation. Regularly wash the painted surface with mild soapy water to remove dirt and grime to improve the performance of the coating. Never use high pressure washers as this can cause coating damage and water ingress into the wall cavity.

Thoroughly inspect topcoat paint work at the end of year 1 and repair areas of damage/coating breakdown according to the original paint specification or approved equivalent. Repeat inspection process at year 5 and based on the results of this condition survey make a decision on future maintenance actions, which may include touch up/repair of areas or a full re-coat.

Additional basic maintenance tasks include but are not limited to; controlling vegetation and garden beds close to the installation, keeping gutters and pipes clear, addressing potential moisture damage due to overflows and replacement of penetrations, flashings and sealants used in installation as required.

Generally, exterior surface coatings deteriorate by chalking rather than flaking. When repainting becomes necessary and the surface is unbroken, remove loose chalk by lightly sanding and follow the preparation steps above. Reapply new coatings in accordance with the paint manufacturer's instructions.

1.7.2 NATURAL PRODUCTS (CLASSIC SHINGLES PLUS NATURAL ONLY)

The extent and nature of maintenance will depend on the geographical location and exposure of the installation. Weathertex may be periodically cleaned with mild soapy water or a suitable timber cleaner. Do not use high pressure washers as this can cause coating damage and water ingress into the wall cavity. Additional basic maintenance tasks include but are not limited to controlling vegetation and garden beds close to the installation, keeping gutters and pipes clear, addressing potential moisture damage due to overflows and replacement of penetrations, flashings and sealants used in installation as required.

Thoroughly inspect any coatings at the end of year 1 and repair areas of damage/coating breakdown. Repeat inspection process at year 3 and based on the results of this condition survey make a decision on future maintenance actions, which may include touch up/repair of areas or a full single coat.

Generally, semi-transparent decking stains and controlled erosion stains are softer and less UV resistant than regular exterior paint resulting in a 3 - 5 year recoating cycle. When re-coating becomes necessary follow the preparation and coating steps above. A darker / more opaque stain colour may be required in time to maintain the desired colour of the boards.

For more information on staining natural Shingles Plus view staining information at weathertex.com.au.

1.8 Steel Frames

The following information applies to Weathertex installed on 0.55 BMT minimum steel frames. Installing Weathertex onto a steel frame is generally similar to installing Weathertex on a timber frame. There is however some differences of which the installer must be aware and the following section outlines the technical information unique to steel frame installation.

1.8.1 FASTENERS

Appropriate fasteners must be used when installing onto steel frames. See the Fasteners Section and in relevant product section to select the correct fastener. Do not tap home under-driven gun nails as this can break the holding power of the fastener. Incorrectly shot nails should be removed and refastened at least 15mm away from the original fastener position.

1.8.2 INSTALLATION

Since 2007 there has been a Thermal Break provision within the Energy Efficiency requirements of the NCC. The provision is included to prevent thermal bridging across the wall cavity. Thermal bridging is a leakage of heat through a conductive path such as metal framing. Thermal bridging causes a reduction in the overall R-value of the wall system, significantly reduces the efficiency of the building's heating and cooling systems and can lead to condensation problems in the wall cavity.

In accordance with the NCC a rigid thermal break with R-value no less than 0.2 must be installed between the Weathertex external cladding and the metal framing members to separate both elements.

When installing Weathertex on a Steel Frame, thermal break battens create a cavity system. Refer to cavity fix construction details for more guidance. Butt-join the stud battens leaving a 5mm gap. Weathertex recommends the following two options as suitable thermal breaks.

1.8.3 RECOMMENDED THERMAL BREAKS

Softwood timber battens are easily installed to provide a suitable thermal break between Weathertex and a steel frame. The softwood timber battens shall be 20mm deep and wide enough to cover the face of the frame. For example if 70x35mm steel frame is chosen, the battens shall be 20x35mm at suitable length.

A suitable membrane must be installed between the steel frame and battens; see section on Wall Sarking Requirements. The membrane must be held in place temporarily, using suitable fasteners or the timber battens, before the battens and the Weathertex are installed.

Final fixings will hold battens firmly in place but they must be temporarily fixed to the frame at 600mm centres before the cladding can be installed.

Extruded polystyrene strips are an alternative to softwood timber battens for a thermal break solution. The extruded polystyrene strips shall be 12mm deep and wide enough to cover the face of the frame. For example if a 70x35mm steel frame is chosen, the battens shall be 12x35mm at suitable length.

Nails or screws cannot be used to secure expanded polystyrene strips to the frame. Instead, double-sided adhesive tape or construction adhesive is suitable to hold the strips in place on the frame. Final fixings will hold extruded polystyrene strips firmly in place.

1.8.4 CAVITY CLOSER

To protect against vermin and other material entering the cavity, the base of the cavity must be sealed using the Weathertex Large or Small Cavity Closer. A cavity closer must be installed at the base of the wall and above window heads and inter-storey flashings. The bottom of each batten is inserted into the cavity closer.

- Use 20mm Large Cavity Closer when using 20mm softwood timber thermal break battens.
- Use 20mm Large Cavity Closer when using polystyrene thermal break strips.
- Use 10mm Small Cavity Closer when using polystyrene thermal break strips.

Fix the cavity closer to the base plate at 300mm centres. Butt-join cavity closers with max 2mm gap as required and ensure the closers are fixed in a straight, level line. It is important that the openings in the cavity closer are kept clear and unobstructed to allow free drainage and ventilation of the cavity.

1.8.5 INSTALLATION

Once the wall has been battened out as per cavity construction details, Weathertex's product specific standard fixing instructions shall be followed to install the cladding on to the frame.

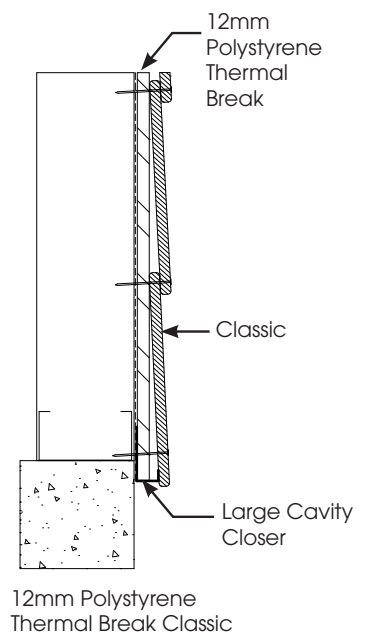
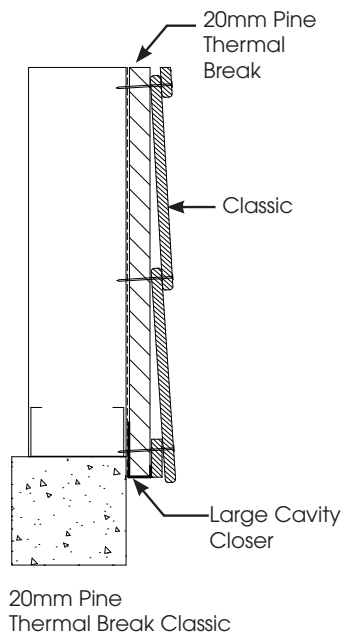
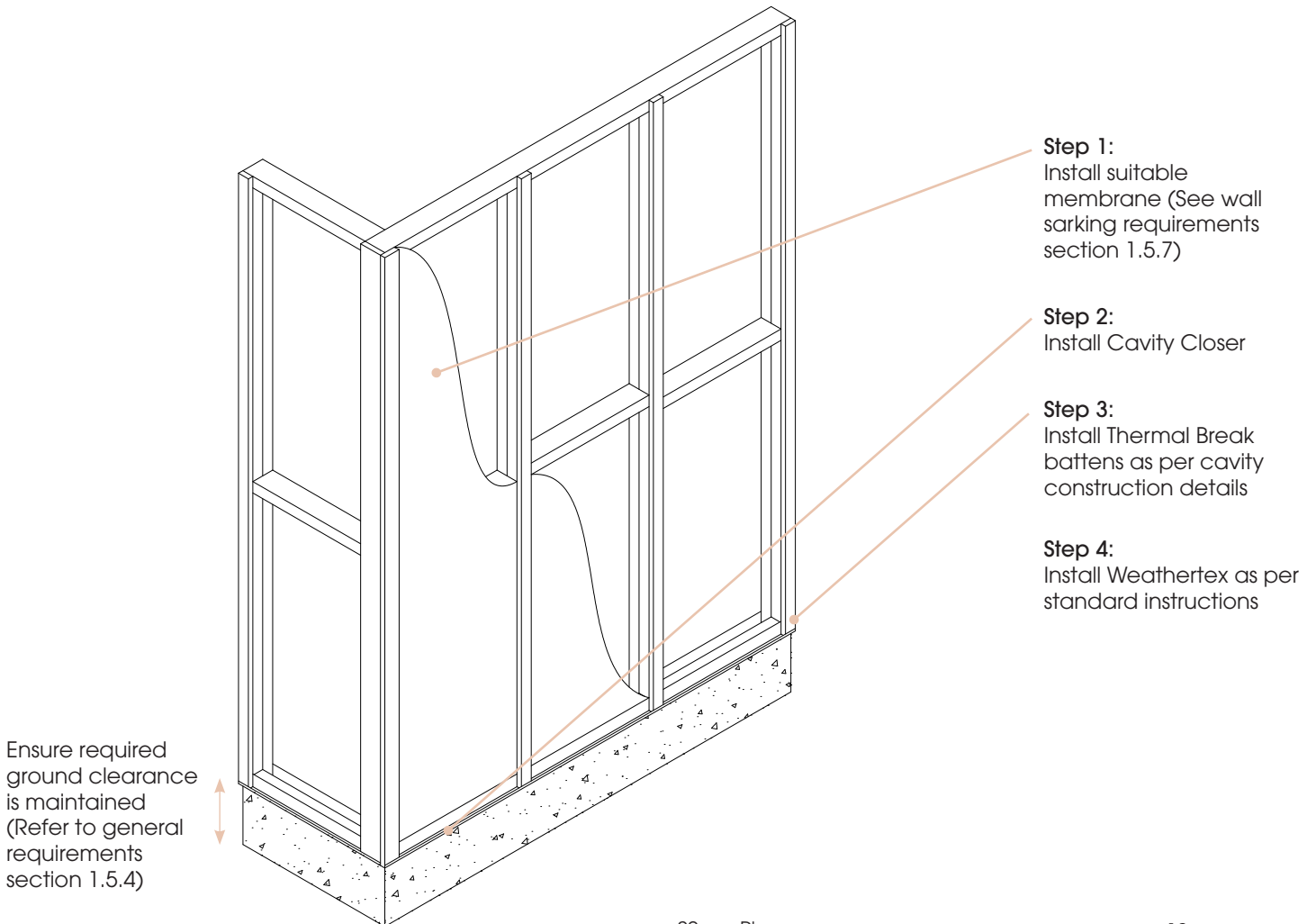

1.9 Cavity System

To provide the best protection for your wall against moisture and mould related problems Weathertex highly recommends the use of a cavity fixing system. Fixing over the Weathertex cavity system provides the best defence for your internal lining, frame, insulation and cladding against sick home syndrome. A cavity system creates a space within the wall that allows airflow to remove any moisture that accumulates in this space either from wind driven rain or condensation.

1.9.1 PREPARATION

Minimum requirements for fasteners must be followed when installing the Weathertex Cavity System. See the Fasteners Section when selecting appropriate fasteners.

A suitable membrane must be installed between the timber frame and battens; see section on Wall Sarking Requirements. The membrane can be secured by the timber battens as they are installed along a wall.

Care should be taken when installing bulk insulation to ensure the stud cavity is not over-filled. Over filling the stud cavity with bulk insulation will impinge in the cavity created by the cavity battens and hence reduce its effectiveness, and may void warranty.

1.9.2 CAVITY BATTENS

Cavity battens provide the separation between the membrane on the wall frame and the cladding. Weathertex provides and recommends the use of Weathertex Cavity Battens which are 1220 x 45 x 9.5mm. Check your local regulations and/or certifiers for recommended batten thickness. If using battens other than Weathertex supplied cavity battens, fastener lengths should be increased to accommodate the batten thickness.

Refer to Weathertex Cavity Fix Construction Details when installing Weathertex cavity battens. Cavity battens must be fastened to framework at a minimum of 600mm centres. Butt-join the stud battens leaving a 5mm gap.

1.9.3 CAVITY CLOSER

To protect against vermin and other material entering the cavity, the base of the cavity must be sealed using the Weathertex Large or Small Cavity Closer. Designed not to interrupt airflow in the cavity, a cavity closer must be installed at the base of the wall, above window heads, inter-storey flashings and at other points where a cavity is created by the design. The bottom of the battens is inserted into the cavity closer.

- Use 20mm Large Cavity Closer for: Classic weatherboards with 9.5mm cavity system

Fix the cavity closer to the base plate at 300mm centres along the closer with 30 x 2.8mm flat head galvanised nails. Butt-join the cavity closers with a max 2mm gap and ensure they are fixed in a straight, level line. It is important that the openings in the cavity closer are kept clear and unobstructed to allow free drainage and ventilation from the top to the bottom of the cavity.

CAVITY
CONSTRUCTION
DETAILS AT

weathertex.com.au

1.9.4 INSTALLATION

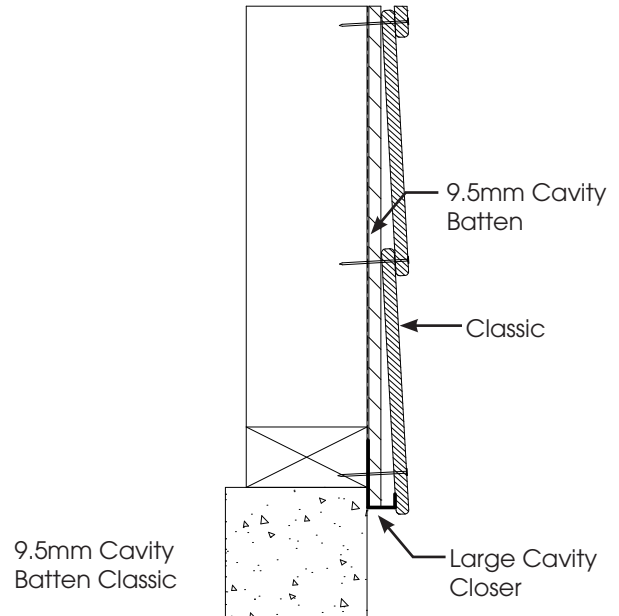
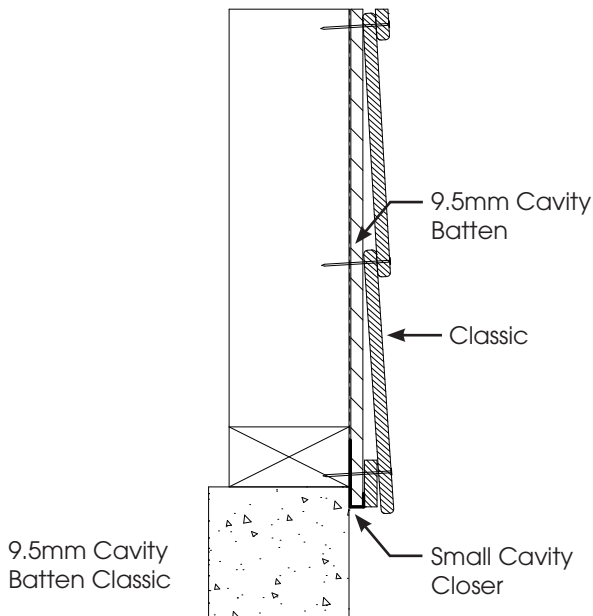
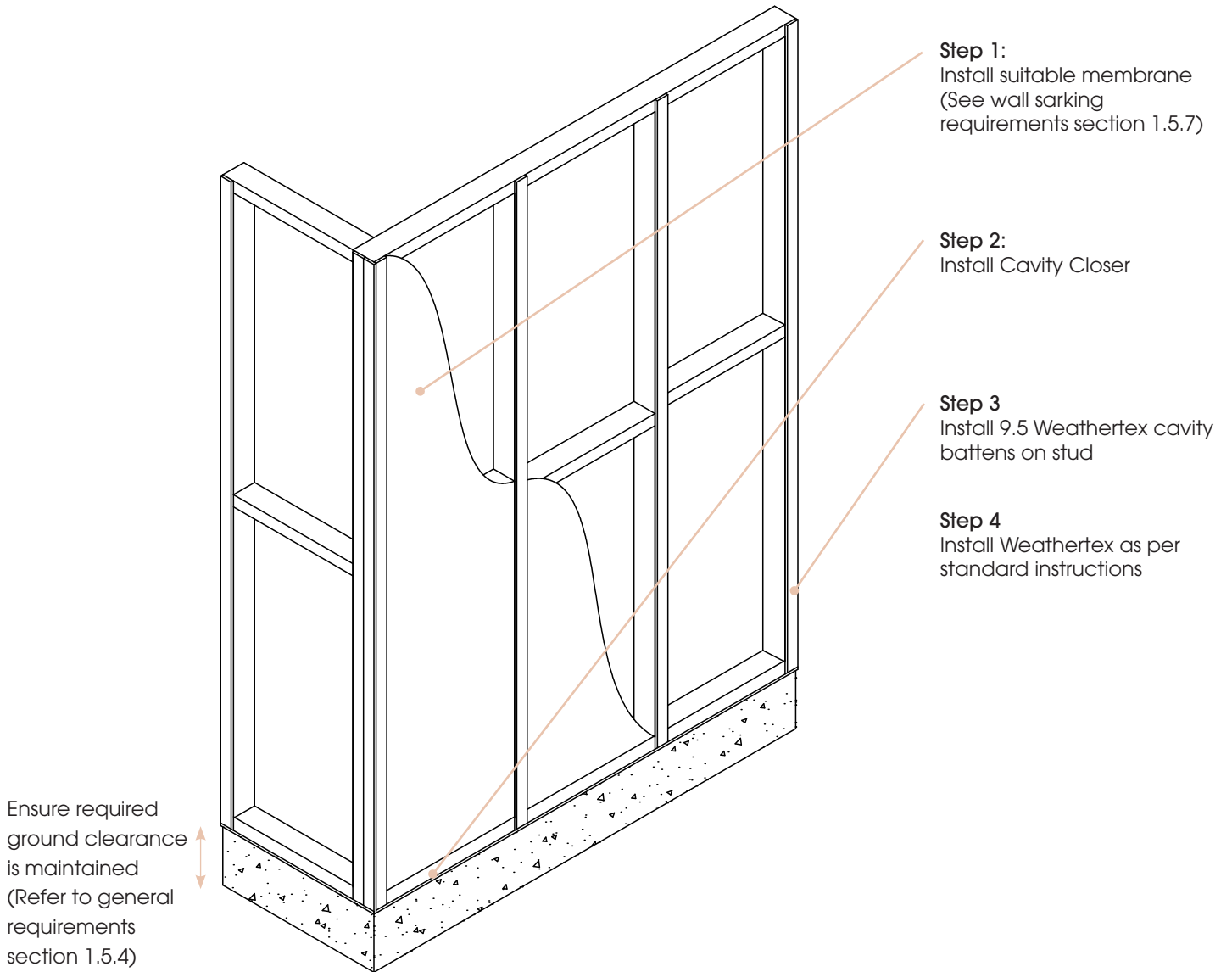

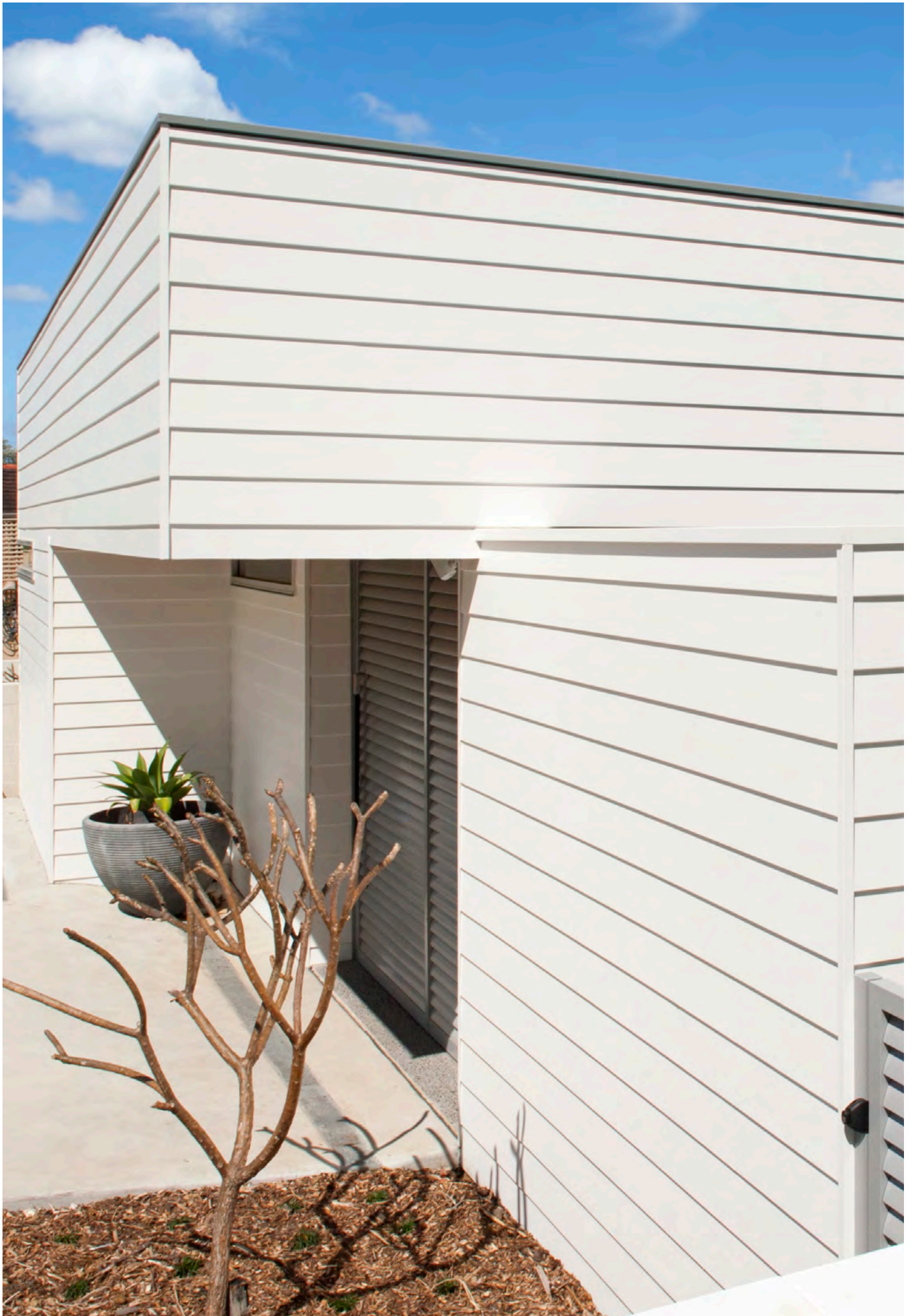

2.1 CLASSIC Weatherboards

2.1.1 CLASSIC WEATHERBOARD BENEFITS

Classic weatherboards are the more affordable lapping weatherboard system requiring traditional or aluminium joining. Weathertex Classic weatherboards are truly an Australian classic. Choose Smooth or Ruff-Sawn surface finishes to create a clean, smart-looking home. They blend perfectly with other building materials providing limitless design and decorative solutions.

Features & Benefits

- Durable with a 25 year warranty on Classic 200, and 10 years on Shingles Plus.
- Off stud joining option enables minimal waste and less timber stud layout.
- Suits a wide range of home designs and styles.
- Value option - perfect for renovations on a tight budget.
- Can be cut with standard carpentry tools.

2.1.2 CLASSIC PRODUCT RANGE

Weathertex Classic product range include smooth and featured surface planks for lapped applications:

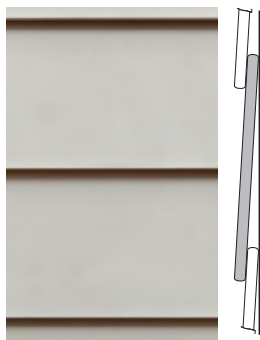

CLASSIC SMOOTH
Width: 200



CLASSIC RUFF-SAWN
Width: 200mm



CLASSIC RUSTICATED SMOOTH
Width: 200mm

Weatherboards are 3660 mm in length and 9.5 mm in thickness.

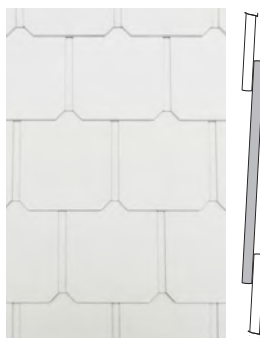

CLASSIC SHINGLES PLUS SMOOTH
Width: 225mm



CLASSIC SHINGLES PLUS NATURAL
Width: 225mm



Shingles Plus are 1196 mm in length, 225 mm width and 9.5 mm in thickness.

To view Weathertex product codes scan QR code.



2.2 Accessories

2.2.1 WEATHERTEX ACCESSORIES *Made from Polycarbonate/ABS

TRADITIONAL OFF STUD JOINER

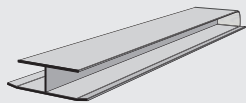

Available in 200 Smooth & Woodgrain.

For traditional joining of Classic 200 Smooth, Classic 200 Ruff-Sawn

RUSTICATED JOINERS

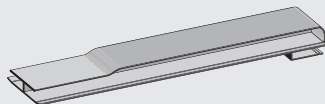

Available in 200 Smooth

For: Classic Rusticated 200 Smooth

2.2.2 TRIMTEC ACCESSORIES *Made from anodised aluminium

PRODUCT

PRODUCT IMAGE

LINE DRAWING

DIMENSION

LARGE EXTERNAL CORNER

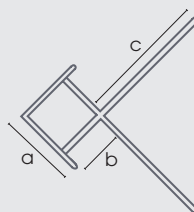
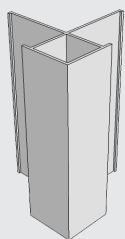

L = 3000mm
a = 27mm
b = 21mm
c = 35mm

LARGE INTERNAL CORNER

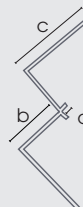
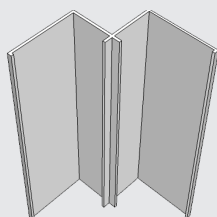

L = 3000mm
a = 4mm
b = 21mm
c = 35mm

LARGE END STOP

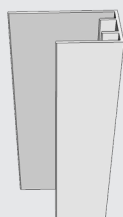

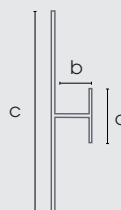
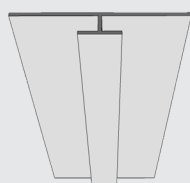

L = 3660mm
a = 27mm
b = 21mm
c = 45mm

WEATHERGROOVE JOINER
(To be cut to 205mm lengths for Shingles Plus joiners)



L = 3660, 2745, 2440mm
a = 12mm
b = 5mm
c = 50mm

2.2.2 TRIMTEC ACCESSORIES *Made from anodised aluminium

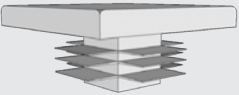
PRODUCT	PRODUCT IMAGE	LINE DRAWING	DIMENSION
LARGE LONG VERTICAL JOINER			L = 3000mm a = 27mm b = 70mm
LARGE CORNER PLUG		Use with Large External corner	

2.2.3 CAVITY WALL SYSTEM (Optional)

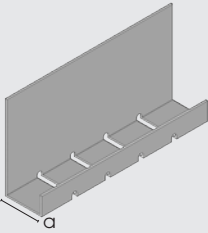
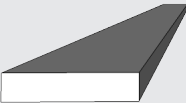
<p>CAVITY CLOSER</p> <p>L = 1830mm a = Lrg 20mm = Sml 10mm</p> 	<p>CAVITY BATTENS</p> <p>1220mm x 45mm 9.5mm thickness For all cavity constructions</p> 
--	--

2.3 Fasteners

Refer to the Wind Tables below when selecting a fastener. For wind ratings above N4 and C2 please contact Weathertex Technical on (ph: 1800 040 080).

Installers must assure themselves that the appearance of the selected fastener is suitable for the intended use. Generally, head sizes in excess of 6mm or T and D head shaped nails may not produce a satisfactory finish on face fixed profiles.

2.3.1 RESIDENTIAL WIND TABLE - AS 4055 WIND CLASSIFICATION

Product	Frame	Fasteners	Non-Cyclonic Wind	Cyclonic Wind	Maximum Stud Spacing	
					General Areas of Walls	Within 1200mm of building edges
Classic 200 / Classic 200 Rusticated	MGP10 Timber Minimum + Direct Fix	50mm x 2.5mm Ring Shank Nail	N1, N2, N3, N4	C1, C2	600	600*
Classic Shingles Plus	MGP10 Timber Minimum + Direct Fix	50mm x 2.5mm Ring Shank Nail	N1, N2, N3	C1	600	600
			N4	C2	600	450
Classic 200 / Classic 200 Rusticated	0.55mm/G550 Steel Minimum thickness + 12mm thermal break	SCROOZ 8g x 42mm FibreFix Cement Board Screw Product Code: FFSC0842T	N1, N2, N3, N4	C1, C2	600	600*
Classic Shingles Plus	0.55mm/G550 Steel Minimum thickness + 12mm thermal break	SCROOZ 8g x 42mm FibreFix Cement Board Screw Product Code: FFSC0842T	N1, N2, N3	C1	600	600
			N4	C2	600	450

*450mm centres needed for Classic 200 Rusticated

2.3.2 COMMERCIAL WIND TABLE - AS/NZS 1170.2 WIND LOADS

Note: Serviceability Limit State (SLS) wind pressures are limited to +1 kPa, -1.5 kPa for V2.2.1/FV1.1 Weatherproofing.

Product	Frame	Fasteners	Design Wind Pressure (Ultimate) kPa	Maximum Stud Spacing
Classic 200 / Classic 200 Rusticated	MGP10 Timber Minimum + Direct Fix	50mm x 2.5mm Ring Shank Nail	1.5*	600
			4**	450
			4	400
			5.5	300
Classic Shingles Plus	MGP10 Timber Minimum + Direct Fix	50mm x 2.5mm Ring Shank Nail	1.5	600
			3.5	450
			4	400
			5	300
Classic 200 / Classic 200 Rusticated	0.55mm/G550 Steel Minimum thickness + 12mm thermal break	SCROOZ 8g x 42mm FibreFix Cement Board Screw Product Code: FFSC0842T	1.5*	600
			3.5**	450
			4	400
			5.5	300
Classic Shingles Plus	0.55mm/G550 Steel Minimum thickness + 12mm thermal break	SCROOZ 8g x 42mm FibreFix Cement Board Screw Product Code: FFSC0842T	1.5	600
			3.5	450
			4	400
			5	300

*Reduce to 1kPa for Classic 200 Rusticated

**Reduce to 3kPa for Classic 200 Rusticated

Fastener Notes:

- Wind classification results have been conducted allowing for maximum packing distances specified in the tables. The fastener length must be increased to accommodate for the thickness of larger battens and/or additional packing materials to ensure the same penetration into the structural subframe.
- The above tables are relevant for off stud joining methods for timber and steel frames.
- The spans of the cladding shall be continuous spans of 2 spans or greater. Simply supported spans are not permitted.
- Span/150 serviceability limit state deflection criteria.
- All fasteners must be galvanised or suitably coated to resist corrosion for external application (Australian Standard AS 3566, Class 3 for screws). When installed in high corrosion zones such as coastal locations, fasteners (nails and screws) must be made of materials appropriate to the desired life of the system and geographical location. Stainless Steel Nails and Class 4 Screws may be necessary in these zones. The advice of the fastener supplier should be sought.
- When using countersunk screws, these may be countersunk 2mm below the board surface and filled with a high quality proprietary grade, acrylic-based flexible paintable filler. Non-flexible epoxy based fillers are not suitable and may crack and fail with movement of construction components. If using a smart-bit style countersinking tool; the gauge of the screw must match the gauge of the tool to prevent movement issues. Screw holes should be spray primed after screwing. Filler should be sanded and area re-primed prior to painting.
- Stainless steel fasteners required if leaving Classic Shingles Plus Natural unsealed or stained.

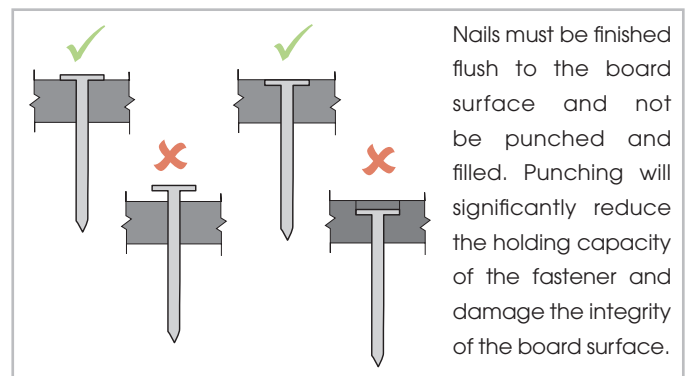

2.4 INSTALL: Classic

The following product specific product installation instructions are applicable for both direct fix (timber frame) and cavity fix (timber and steel frame). Installation instructions in this section are to be used in conjunction with information and requirements given in previous sections and the national and state building codes.

2.4.1 BASE OF THE WALL & FRAME PREPARATION

Check and straighten sub-structures as required. Establish ground clearance and weatherboard overhang requirements. For cavity installation see cavity systems (section 1.10)/steel frames (section 1.9). For direct fix install wall sarking prior to installation, refer to AS 4200.2. Install appropriate flashing at the base of the frame to ensure separation of Weathertex from any concrete slabs.

2.4.2 CLASSIC WEATHERBOARDS INSTALLATION

Establish a horizontal datum around the perimeter of the building, measure wall height from the datum to establish the number of weatherboard rows required. Minimum overlap of 20mm for Classic and a minimum overlap of 25mm for Rusticated planks.

First Row: Fix a 35mm x 9.5mm strip of Weathertex weatherboard 5mm up from datum. Level the bottom edge of the weatherboard to the datum line. Fasten the bottom edge through the weathertex strip into the frame. Fit joiners as work proceeds.

Successive Rows: Use the storey rod, lap gauge or joiner to position weatherboards and maintain uniform rows. Check rows for level, a laps fasten through weatherboards into stud. One fastener per stud located 12mm from bottom edge and the ends of the board. Row heights around corners should be checked as work progresses to prevent creep.

Please refer to construction details found on the Weathertex website for all window, doors and penetrations.

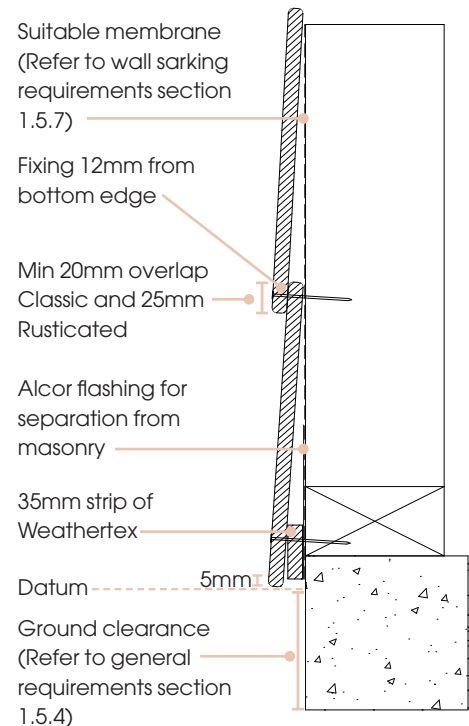

2.4.3 SHINGLES PLUS INSTALLATION

Shingles are the only product in the Weathertex Natural range that Weathertex permits painting. If you are painting the shingles you will need to use a high quality tannin blocking exterior timber primer (water or solvent based) to prime the shingles and any cut edges.

First Row: Set a horizontal datum line to align the first row. Allow a minimum overlap of 40mm. Fix a 35mm x 9.5mm strip of Weathertex 25mm up from the datum. Level the bottom edge of the board with the datum line. Fasten the bottom edge through the Weathertex strip into the timber framing. Cut Weathergroove joiner into 205mm joiners, fit these joiners as work proceeds. Where weathertightness is required add a bead of suitable sealant in each groove where the next row overlaps.

Successive Rows: Use the storey rod or lap gauge to position weatherboards and maintain uniform rows. Check rows for level. At laps, fasten through both Shingles into the stud. Use one fastener per stud, located at least 30mm from bottom edges and 12mm from ends. Fasteners per fastening guide for classic planks.

Please refer to construction details found on the Weathertex website for all window, doors and penetrations.

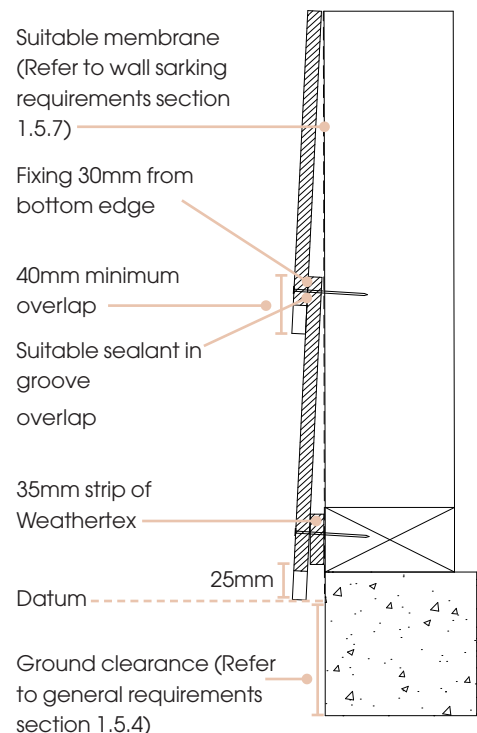

2.4.4 CONSTRUCTION DETAILS

Please refer to Weathertex Direct Fix Installation – Classic, Drgs. of 13.05.22 (18 pages), and Weathertex Cavity Installation – Classic, Drgs. 13.05.22 (18 pages) for details relevant to the Classic Weatherproofing Appraisal.

2.4.5 JOINING DETAILS

To accommodate movement, Weathertex’s joining methods have been designed to provide the correct spacing between adjoining planks, and cover changes in dimensions of the product for specific wall lengths. Refer to length of wall requirements when choosing a joining method. Any cut ends must be primed with a high quality tannin blocking exterior timber primer (water or solvent based).

2.4.5.1 JOINING: CLASSIC WEATHERBOARDS

Form joints between weatherboard ends using the relevant joiners for the selected profile - refer to the Accessories Section. Stagger joints randomly or brick lay throughout the wall with joints being formed midway between the studs. When fitting the joiner, bring the ends into moderate contact with the splayed edges or nibs within the joiner. Do not force ends tightly together. It is advisable to prepaint plank ends when using Traditional Joiners to avoid white lines either side of the Accessory after possible contraction of construction components in dry conditions. Simply cut joiners to fit at window heads, sills and eaves as required.

NOTES:

1. Avoid penetrating PC/ABS joiners with fixings during the installation process. This may cause the joiner to crack after the installation. Where necessary predrill the fixing position through the joiner prior to fixing.
2. On the first row of Weathertex Rusticated remove leg gauge from the back of the joiner
3. Refer to length of wall requirements for continuous walls over 11m long.

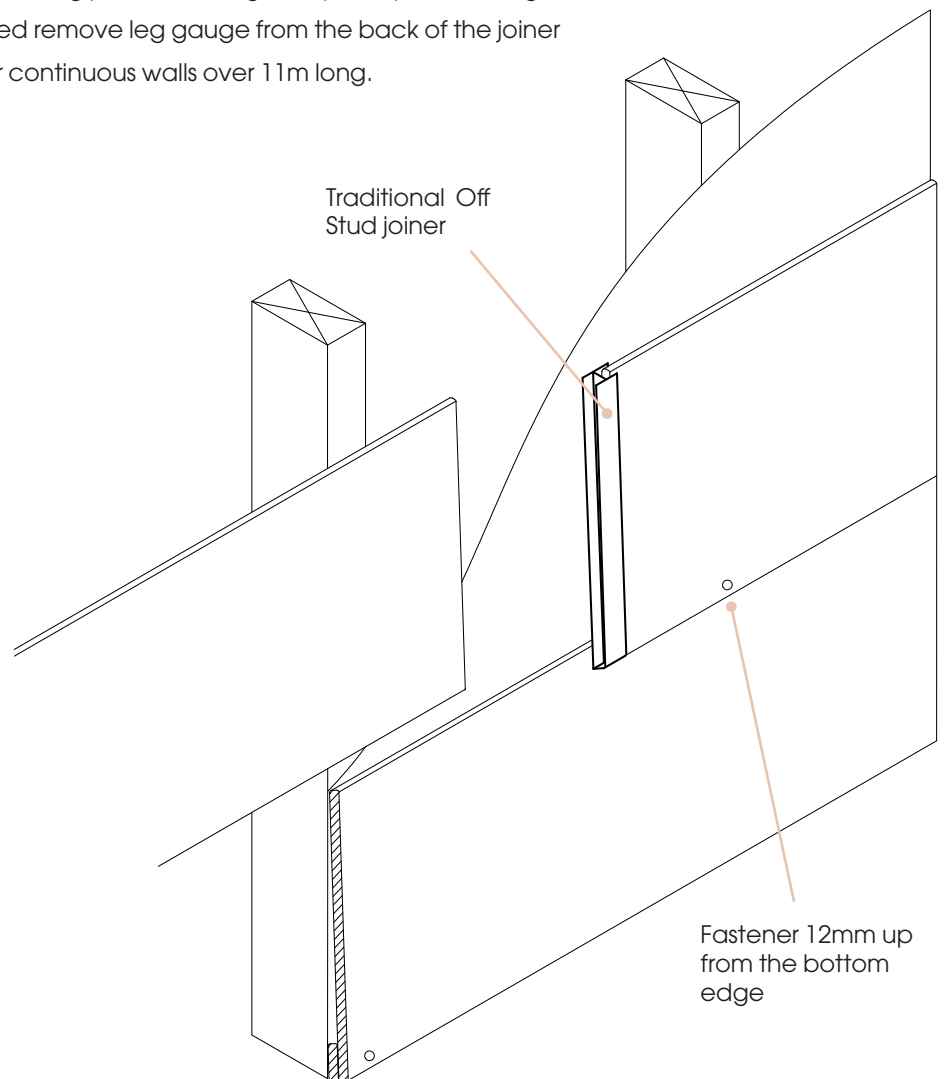

2.4 INSTALL: Classic

2.4.5.2 JOINING: CLASSIC WEATHERBOARDS - LARGE LONG VERTICAL JOINER

For quick and sleek installation, align weatherboards to form a single vertical control joint using the Trimtec Large Long Vertical Joiner. It is advisable to prepaint plank ends when using Long Vertical Joiners to avoid white lines either side of the Accessory after possible contraction of construction components in dry conditions.

Joiner must be positioned on a double stud.

Joiner may be etch primed and painted or left as the original uncoated anodised aluminium finish.

1. Attach the aluminium joiner to the stud frame through the back flange at 1200mm centres with a flat head nail.
2. Nibs in the joiner provide correct control joint spacing. Do not install tight to the nibs.
3. Planks may be slightly bowed to fit between two vertical joiners or slid in place from the top before fastening off.

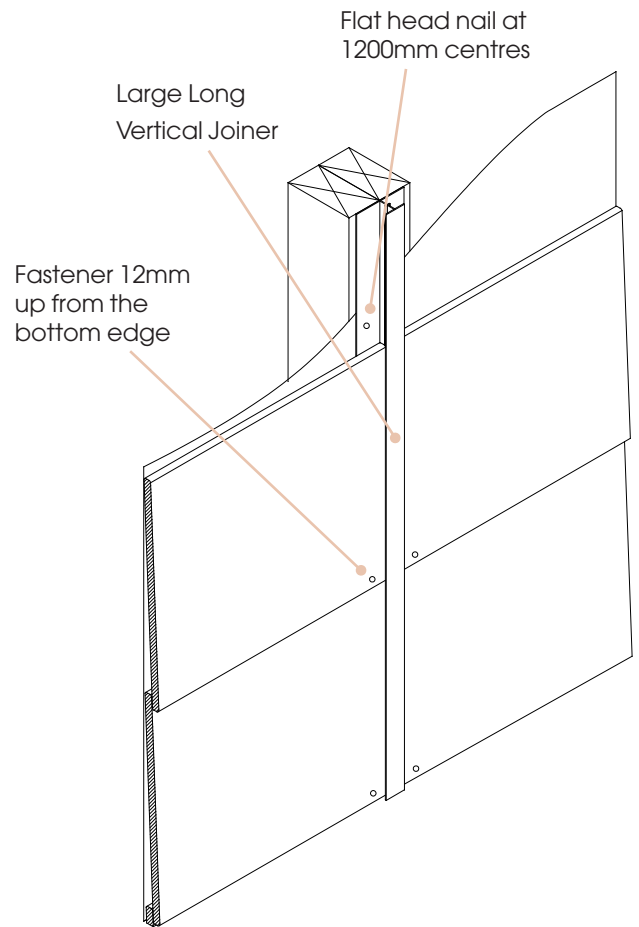

2.4.5.3 JOINING: SHINGLES PLUS

Form joints between weatherboard ends using the 205mm cut lengths of Weathergroove joiner - refer to the Accessories Section. Add a small bead of polyurethane sealant/adhesive at the top of the joiner under the lap to ensure that the joiner cannot slip. Stagger joints randomly or brick lay throughout the wall with joints being formed midway between the studs. Simply cut joiners to fit at window heads, sills and eaves as required.

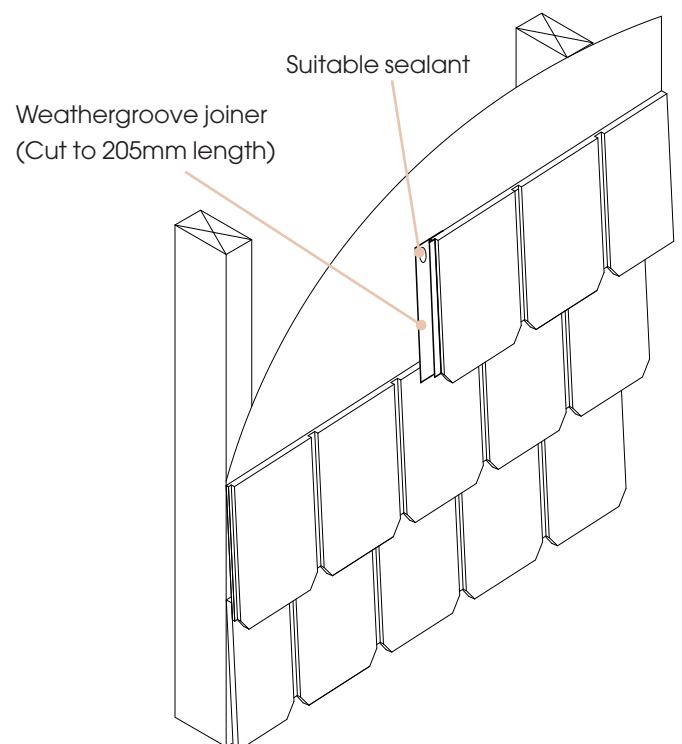

MANUFACTURER'S WARRANTY

1. Weathertex Pty Ltd A.B.N 67 084 713 986 ("Weathertex") warrants that the Products supplied are of first quality, free from material defect in materials, design and workmanship, and in conformity with the technical specifications detailed in the published Weathertex Installation Guide that is current at the date of purchase. This statutory warranty applies for a period of 12 months from the date of purchase in addition to the following clauses.

2. Natural Board - Weathertex warrants that its Natural (Brown) Board Products will not rot, split or crack for a period of 10 (ten) years from the date of purchase when installed and maintained in accordance with Weathertex's current published materials.

Pre Primed Classic Shingles Plus, EcoWall and Rubix Panel - Weathertex warrants that its EcoWall Products will not rot, split or crack for a period of 10 (ten) years from the date of purchase when installed and maintained in accordance with Weathertex's current published materials.

Pre Primed Board - Weathertex warrants that its pre primed board Products will not rot, split or crack for a period of 25 (twenty-five) years from the date of purchase when prepared, installed and maintained in accordance with Weathertex's current published materials.

3. A reference to Products in these warranty terms and conditions does not include accessory products listed "Accessories" in the Weathertex Price List ("Accessory Products"). Weathertex warrants that the Accessory Products will be free from defect in material and workmanship for a period of 7 years from the date of purchase. For the purposes of clarity, the warranties provided in clause 1 and 2 do not apply to Accessory Products.

4. The benefits to the purchaser given by the warranties set out in clauses 1 to 3 are in addition to other rights and remedies of the purchaser under Australian Consumer Law in relation to the Weathertex products and accessories.

CONDITIONS OF THE WARRANTY

5. The warranties provided in clauses 1, 2 and 3 are only available to the original purchaser ("Purchaser") who provides Weathertex with proof of purchase and who makes the claim in writing within 30 days from the point in time when the defect becomes apparent or should have become apparent.

6. Weathertex will not be liable for any warranty claims made under clauses 1 and 2 if any of the following apply:

(a) the Products are not installed used or maintained in accordance with applicable instructions and/or specifications, including installation and site conditions provided by Weathertex (including the published Weathertex Installation Guide that is current at the date of purchase);

(b) the building in which the Products are installed does not comply with all relevant Building Codes and Regulations, Standards, and Council/Authority/Regulator requirements;

(c) the Purchaser has not complied with any service instructions which Weathertex may give or any subsequent request as to a modification of the Products which Weathertex may make from time to time in writing;

(d) the defect is caused by the use of materials, parts or accessory products that are not supplied, recommended, or approved by Weathertex;

(e) the Products are not maintained, prepared or installed by authorised installation contractors in circumstances where Weathertex has directed the Purchaser to ensure that the Products are maintained, prepared or installed by such authorised installation contractors; or

(f) the repair, rectification or replacement of the Products is required as a result of normal wear and tear or necessitated in whole or in part by the fault or negligence of any person other than Weathertex.

7. Further to clause 6 and without limiting clause 6, Weathertex under no circumstances will be liable for any claims, damages, or defects arising from or in any way attributable to:

(a) acts of God, fire, flood or other severe weather conditions or unusual climatic conditions;

(b) performance of paint/coatings applied to the Products;

(c) development of any algae, bacteria or fungi on the Products (whether on the exposed or unexposed surfaces);

(d) poor workmanship; or

(e) any other losses or damages (whether direct or indirect) including property damage or personal injury, consequential loss, economic loss or loss of profits arising in contract or negligence.

8. The Product is subject to natural variation in finish and presentation as a result of the manufacturing process. The purchaser / builder / installer must ensure the Product meets aesthetic expectations prior to installation. Subject to the terms and conditions of this warranty, after installation of the Product, Weathertex is not liable for claims arising from aesthetic surface variations if such variations were, or would upon reasonable inspection have been apparent prior to the installation.

REMEDIES

9. Should the Purchaser's warranty claim made under clauses 1 and/or 2

be valid within the relevant warranty period, then the remedy provided by Weathertex will be limited to either of the following (where possible) as chosen by Weathertex:

(a) Weathertex replacing the Products provided the claim is accepted by Weathertex and subject to such replacement Products being available in the manufacturing inventory at the time the claim is accepted by Weathertex. Otherwise, Weathertex will provide such replacement Products when they become available.

(b) Weathertex repairing the Products provided the claim is accepted by Weathertex.

10. Should the Purchaser's warranty claim made under clause 3 be valid, then the remedy provided by Weathertex will be limited to Weathertex replacing the Accessory Products provided the claim is accepted by Weathertex and subject to such replacement Accessory Products being available in the manufacturing inventory at the time the claim is accepted by Weathertex. Otherwise, Weathertex will provide such replacement Accessory Products when they become available.

11. The Purchaser is not entitled to any other remedies (that is apart from the remedies detailed in clauses 8 and 9) with respect to a warranty claim under clauses 1, 2 or 3.

12. This warranty cannot be relied upon by any other person and is not transferable.

13. Any replacement works will be conducted in accordance with the Building Codes and Regulations, Standards, and Council/Authority Regulator requirements applicable at the time of construction. Where the Building Codes and Regulations, Standards, and Council/ Authority Regulator requirements have changed after the Products were purchased, Weathertex will not be responsible for any costs associated with ensuring that the replacement works comply with the updated Building Codes and Regulations, Standards, and Council/Authority Regulator requirements.

14. Where an approved claim requires re-coating of the Products the Purchaser acknowledges and agrees to accept minor colour variations between the existing or original colour and the re-coated replacement Products or rectification areas.

15. Except as provided for in these terms and to the fullest extent permitted by law, all terms, statements, warranties and conditions whether express, implied, statutory or otherwise, relating to the Products, the Accessory Products, the subject matter of these terms or to these terms generally are excluded. Nothing contained herein excludes or modifies any rights the Purchaser may have under the Australian Competition and Consumer Act 2010 (or equivalent in other countries as determined by Weathertex in its sole discretion).

DISCLAIMER

16. Recommendations made by Weathertex are based on good building practice and are not a complete statement of all relevant data. As the installation of the Products is influenced by and relies on factors outside the control of Weathertex, Weathertex assumes no responsibility for works/ systems used in connection with the installation of the Products and their suitability to satisfy relevant Building Codes and Regulations, Standards, and Council/Authority /Regulator requirements.

17. Unless specifically stated otherwise, the warranties under clauses 1, 2 and 3 apply only to Weathertex products purchased and installed according to the Weathertex Installation Guide in Australia, New Zealand and the Weathertex International Installation Guide.

AUSTRALIAN CONSUMER LAW

18. Our goods come with guarantees that cannot be excluded under the Australian Consumer Law. You are entitled to a replacement or refund for a major failure and compensation for any other reasonably foreseeable loss or damage. You are also entitled to have the goods repaired or replaced if the goods fail to be of acceptable quality and the failure does not amount to a major failure.

MAKING WARRANTY CLAIMS

19. The claimant (being the Purchaser) must make all warranty claims in writing. The claimant must be the original purchaser of the Weathertex product and must retain the purchase receipt (in relation to the purchase of the product) as proof of purchase. Proof of purchase must be provided to Weathertex as part of the warranty claim.

Warranty claims (and claims for reasonable costs and expenses in making the claim as referred to in clause 18) can be addressed to Weathertex by post, fax or via e-mail as follows:

The Manager
Weathertex Pty Ltd
PO Box 21
Raymond Terrace NSW 2324
Phone 1800 040 080
Fax 1800 647 926
E-mail sales@weathertex.com.au

20. Weathertex will respond to all warranty claims. This response may include an inspection by a Weathertex representative of the installed Product. The claimant will bear all costs and expenses of making the claim. However reasonable costs and expenses will be reimbursed to the claimant in the event that the claim is accepted by Weathertex.

As of 14th August 2020.



13

Classic Smooth, Selfok Ecogroove 150 Natural & Weathergroove 150 Smooth



Weathertex® is made in Australia by
Weathertex Pty Ltd ABN 67 084 713 986

PO Box 21, Raymond Terrace NSW 2324

CONTACT WEATHERTEX FOR INFORMATION OR ADVICE

1800 040 080 | weathertex.com.au

When specifying or installing Weathertex products, please make certain that you have the most current installation manual and technical information. To view the latest installation manual, scan the QR Code or visit weathertex.com.au

UPDATED 2ND FEBRUARY 2022 VERSION CC020222

